

**Texas Instruments
Home Computer
Accessory**

**Disk Memory
System**



The system consists of a Disk Drive Controller,
a Disk Manager Command Module, and 1 to 3
Disk Memory Drives (sold separately).



TEXAS INSTRUMENTS
INCORPORATED
DALLAS, TEXAS

Disk Memory System

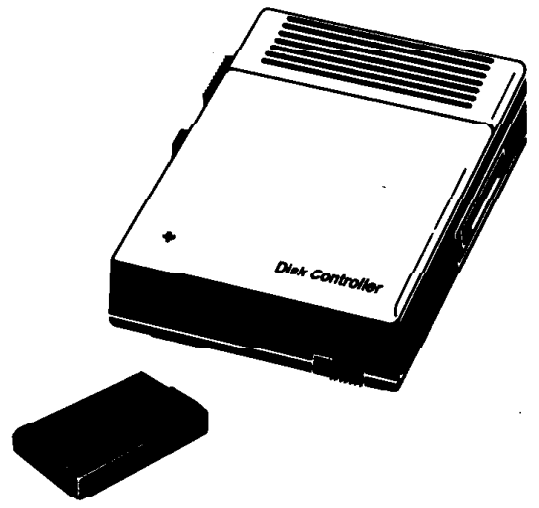

Operating instructions for the
PHP1800 Disk Drive Controller,
the PHM3019 Disk Manager Command Module,
and up to three PHP1850 Disk Memory Drives.

IMPORTANT

Record the serial number from the bottom of the Disk Drive Controller and purchase date in the space below. The serial number is identified by the words "SERIAL NO." on the bottom case. Always reference this information in any correspondence.

PHP1800		
Model No.	Serial No.	Purchase Date

Copyright © 1980 Texas Instruments Incorporated
Command Module program and data base contents
copyright © 1980 Texas Instruments Incorporated.
See important warranty information at back of book.

TABLE OF CONTENTS

Introduction	1
Features of Your Disk System	2
Diskette Information	4
Write-protecting Diskettes	5
Labeling and Handling Precautions	5
Set-Up Instructions	7
General Notes	8
Connecting the Controller	9
Connecting the Disk Drives	10
Powering Up the System	11
A Quick Look at the Disk System	13
Disk Manager Command Module Operation	17
Editing	18
File Commands	18
Disk Commands	20
Disk Tests	25
Single Disk Processing	27
Disk System Operation with TI BASIC	28
Saving and Loading Programs	28
File Naming Conventions	29
File Processing	29
Cataloging Files	38
Sample Programs	39
Appendix A: Error Codes in TI BASIC	44
Appendix B: Error Codes in the Disk Manager Command Module	46
Appendix C: Diskette/Cassette Operations	48
Transfer Programs between Cassettes and Diskettes	48
Transfer Data from Cassette to Diskette	48
Service and Warranty Information	50
In Case of Difficulty	50
Diskette Failure Indicators	50
Exchange Centers (Local Service Options)	51
If You Have Questions or Need Assistance	51
Warranty	52

INTRODUCTION

The Texas Instruments Disk Memory System is a powerful combination of computer hardware and software that allows you to store and retrieve data quickly and accurately on 5-1/4 inch diskettes (sold separately). The system consists of the following components:

DISK MEMORY DRIVE — The disk drive reads information from and writes information on the diskette. It can rapidly locate any position or file on the diskette as directed by the Disk Drive Controller. The disk drive spins the diskette at a constant speed and controls the movement of the magnetic head. You may have one of two drives that have slightly different appearances. However, they function in exactly the same way. Diskettes (not included) are required.

DISK DRIVE CONTROLLER — The Disk Drive Controller tells the disk drive where to position the magnetic head in order to read or write information properly. The controller also puts an index on the disk, making the data that has been written easy to locate.

DISK MANAGER COMMAND MODULE — The Disk Manager *Solid State Software*™ Command Module helps you maintain the information on your diskettes. Naming and renaming diskettes, renaming files, deleting files, copying files, and copying diskettes all can easily be performed with the Disk Manager module plugged into the computer console.

The Texas Instruments disk system represents a major advance over other systems. Because the control software needed for the disk system is in permanent ROM, in the Disk Manager Command Module, and in the controller, the disk system uses a relatively small amount of working space in the computer's available memory (RAM). The Disk Manager Command Module provides many advanced functions. For instance, in copying a diskette it rearranges the files on the diskette alphabetically. And, if you like, you can copy selected files instead of an entire diskette, quickly and easily. These and many other unique features of the disk system are described in this manual.

Get the most from your disk system by first reading this manual and performing the examples as you go. Also review the appendices for special information and applications. Then use the disk system with your own applications.

Features of Your System

The most important use of the disk system is storage and retrieval of information via TI BASIC programs. Through the proper BASIC commands, you can:

- **SAVE PROGRAMS** — Each diskette holds over 720,000 bits of information. As an example, you can store about 100 BASIC programs, each 50 lines long, on a single diskette.
- **STORE AND RETRIEVE DATA** — You can store data that is accumulated when your programs are run. One disk can hold about 90,000 characters.
- **UPDATE DATA** — You can, through a BASIC program, update the information in your files so that they contain the latest, most accurate data.

The Disk Manager Command Module can also be used to maintain information about the diskettes, such as the name of the diskette and the names of the files. Using the Disk Manager module you can:

- **INITIALIZE DISKETTES** — You can prepare diskettes for use by the system. The initialization routine provides the diskette with header information for each sector. Each diskette must be initialized before initial use.
- **NAME DISKETTES** — Each diskette is given its own name, so that the computer can verify that the proper diskette is in place.
- **RENAME, DELETE, AND COPY FILES** — These functions, of course, can be performed via TI BASIC; however, the Disk Manager Command Module helps you quickly and easily rename files, delete files, and make copies of files.
- **MODIFY PROTECTION** — You may want a file protected so that it cannot be accidentally erased or changed. You can use the Disk Manager Command Module to protect files and, when you want to change them, to release them from protection.

-
- **COPY DISKETTES** — Diskettes and your disk system are a very reliable storage medium. However, under certain circumstances, the data stored on a diskette can be totally or partially lost. For instance, if electrical power fails while the disk drive is writing on a diskette, some data could be lost. To protect your data, it is customary to make backup diskettes. The Disk Manager module makes it easy to copy diskettes for backup even if you have only one disk drive.
 - **PERFORM TESTS** — To ensure that the disk system is operating correctly, the Disk Manager Command Module offers two different tests. The first checks several general areas to see that things are as they should be. The second is an exhaustive test. At the end of the tests, all data on the diskette may have been removed. Before you make a destructive test, you should make a backup copy of the diskette so that your data is not lost.

Certain other Command Modules also operate with the disk system to save and read your files more quickly than with cassettes or other storage media. See the manuals for each module for further information.

DISKETTE INFORMATION

Your disk system requires 5-1/4-inch, single-sided, single-density, soft-sectored diskettes. These diskettes are constructed of a highly flexible plastic film, coated with a thin layer of iron oxide which can be magnetized in very small areas without affecting surrounding areas. The computer interprets these areas of magnetization as coded information.

Note: A diskette comes in a protective jacket, inside a storage envelope. For best results, keep the diskette in the storage envelope except while using. Never remove the diskette from its protective jacket.

Each diskette is divided into tracks, which are 40 (on some diskettes only 35) concentric circles. The tracks are numbered from 0 to 39 (or 34), starting at the outside track. Each track, in turn, is divided into nine sectors. There are thus 360 (or 315) sectors, each of which can contain up to 256 bytes of information, or 2048 tiny magnetized areas. The sectors are numbered 0 through 359 (or 314), starting with sector 0 of the first track and going to sector 8 on the last track. Each sector has additional space used only by the controller to verify sector identification and data accuracy.

The disk controller uses sectors 0 and 1 to form an index of file locations. If those sectors become damaged and unreadable, the computer cannot locate any files on the diskette, and the contents of the entire diskette will be unusable.

To use your disk drive system, insert the proper diskette, and use TI BASIC or a Command Module designed to operate with the disk system. The work of keeping track of your files and reading from or writing on the proper place on the disk is taken care of by the system.

Diskettes can be named for reference purposes. The name of a diskette can be up to ten characters long and may use any characters except the period and the space character. Valid names for diskettes include

DISK21	MYDISK	MY_DISK	PRK_DATA
TIRK_DATA	GEORGE	BACK_UP	BU03/24/80

The following are not valid diskette names.

3.1416	MY DISK	THISNAMEISTOOLONG
--------	---------	-------------------

Write-Protecting Diskettes

Diskettes have a notch in the edge of their protective container. As long as the notch is left open, the drive functions normally. Covering the notch with a piece of special tape provided with the diskette prevents writing on the diskette. When you have a diskette containing programs or data that you want to protect, cover the write-protect notch. Then the information cannot be accidentally written over. If you want to write on the disk later, the tape can be removed.

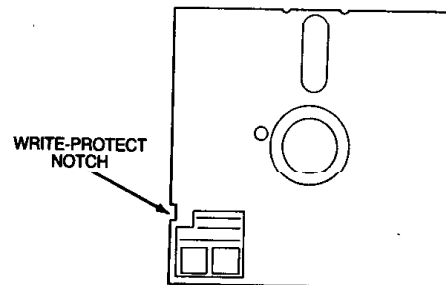

Labeling and Handling Precautions

In handling diskettes, be very careful not to touch the diskette itself. Handle it gently by its protective cover.

Do not write on the protective jacket with a pencil or ballpoint pen since these could damage the diskette. Use a marker pen and light pressure or write what you wish on a label and then put the label on the protective jacket. Adhesive labels are available from many sources.

Any magnet or magnetic field can affect data on a diskette. Do not bring any magnet near a diskette, and do not put a diskette near or on top of anything that generates a magnetic field, such as a television, a monitor, a speaker, etc. Also be aware of more obscure magnetic sources, such as magnetic cabinet latches, magnets in children's toys, and magnetic note holders. As a general rule, do not store diskettes within three feet of any magnetic source.

The magnetic head that reads and writes information on the diskette touches the diskette's surface during operation. If dust or lint is on the surface, it may be ground into the diskette's surface, scratching it. For best results, keep the door on the front of each disk drive closed except when inserting or removing a diskette.

CAUTION

Never put a diskette in the drive until the controller and disk drive are properly connected and power is turned on to all units. Also, never insert or remove diskettes when the drive light is on. And never have a diskette in the drive when removing the cable. Diskettes should always be stored in their protective jackets.

To insert a diskette in the disk drive, first open the disk drive door on the front of the unit. Hold the diskette gently by the corner nearest the write-protect notch, and insert it into the drive with the notch to the left. Close the door carefully.

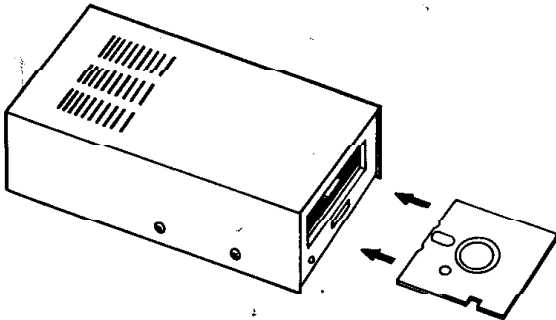

To remove the diskette, open the disk drive door, and extract the diskette. Store it in its storage envelope.

SET-UP INSTRUCTIONS

Carefully unpack the Disk Memory Drive and its cable. The disk drive is a precision device which uses moving parts with exacting tolerances, so handle it carefully. Save the packing materials and cartons so that you can safely transport the unit later.

The drive as it comes from the factory is ready to run as the only drive on your system. If you are using more than one drive, the following process must be done to all but one of the drives that you are using. The last drive should be connected without being altered.

DO THE FOLLOWING ONLY IF YOU ARE USING TWO OR THREE DRIVES!

1. **WARNING: ALL POWER CORDS MUST BE DISCONNECTED FROM THE POWER OUTLETS DURING THE FOLLOWING PROCEDURE!**
2. On all but one of your drives, use a Phillips head screwdriver to remove the six screws that hold the cover. Lift the cover off.
3. Locate the main printed circuit board. On it, locate the termination resistor pack. It has 14 leads and looks like an integrated circuit. (The main boards look slightly different on the two different kinds of drives, but the pack is in the same place on each.) Be careful not to disturb the strapping pack (which is also removable) located very near the resistor pack.

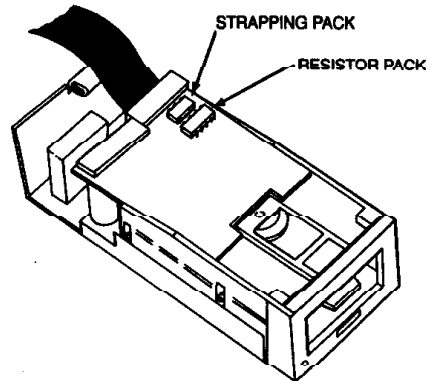

4. Remove the termination resistor pack by prying each end up slightly with a small screwdriver and then lifting it out by your thumb and forefinger. Pull straight up.

5. Save the single drive termination resistor pack so that you can reinsert it if the drive is ever to be used as a single or last disk drive. Note that if the socket for the resistor pack has more holes than there are pins on the pack, install the pack toward the outer edge of the circuit board, leaving the unused holes toward the center of the board.
6. Reattach the cover on the drive, aligning and tightening the screws carefully. **DO NOT OPERATE ANY UNITS WITHOUT REATTACHING THE COVER.**

General Notes

The drives should be located conveniently so that you can insert and remove diskettes. The drives should be placed horizontally. Stacking of disk drives increases internal temperatures and may adversely affect the diskettes.

Disk drives and diskettes are affected by static electricity, magnetic fields, and dust. The drives should not be near the monitor screen, as it generates a powerful magnetic field. If possible, the drives should be in a low humidity, dust-free environment, free from static electricity. If static electricity is a problem in your area, treating your carpet with an anti-static preparation may be helpful.

Setting up the controller and disk drives is a simple process. First, connect them to the Home Computer, and then test their operation. The steps involved in both procedures are included in this section. Information about connecting accessory devices is also included. Please read this material completely before proceeding.

Note: No more than three accessories can be attached in series to the accessory connector on the right side of the computer console. If a *Solid State Speech™* Synthesizer is attached to the computer, it must be connected to the console first.

Other accessories, including the controller, can be connected in any order after the speech unit.

CAUTION

The electronic components of the controller and disk drives can be damaged by static electricity discharges. To avoid damage, do not touch the connector contacts or expose them to static electricity.

Once you've unpacked the units and made any modifications necessary to the disk drives, you're ready to connect the units to the Home Computer.

Connecting the Controller

1. Turn off the computer console and all attached devices.
2. The console connector on the controller projects from the left side of the unit. Place the unit so that its connector is to the right of and parallel to the computer console.
3. A small sliding door protects the accessory connector on the right side of your computer. Carefully slide this door upward so that the connector is visible.
4. Make sure the console and the controller are parallel, with the connectors aligned. Then hold the console firmly with your left hand and gently push the controller connector onto the console connector.

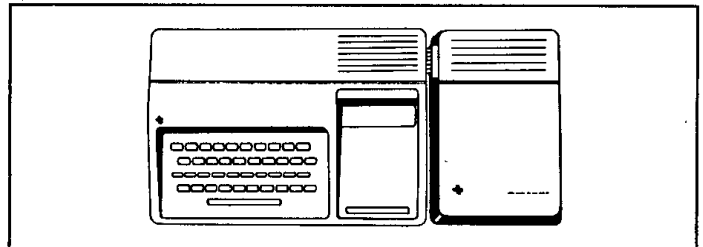

CONSOLE AND CONTROLLER

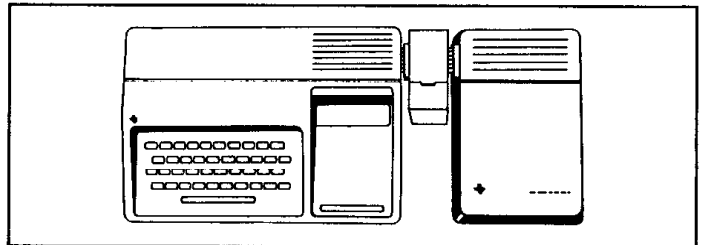

CONSOLE, SPEECH SYNTHESIZER, AND CONTROLLER

Connecting the Disk Drives

Each drive has an attached cable with two connectors, one at the end of the cable and one near the middle of the cable. The connector on the end goes into the port on the rear of the controller or, in the case of multiple disk drives, into the middle connector on the preceding drive unit, using the adapter board (see illustration below). *Note:* It may be necessary to rotate the connector in order to insert it. It goes in easily if you have it positioned correctly.

If you have one drive, connect it to the controller. (Remove and save the adapter board in the event a drive is added later.)

If you have more than one drive, connect them to the controller in series, with all but the last one (the one farthest away from the controller) modified as described above. Connect the first drive to the port on the rear of the controller. The connector on the end of the second drive's cable plugs into the adapter board in the middle of the first drive's cable. The third drive is connected to the second drive in the same way. Whether you have two or three drives, the drive farthest away from the controller should be the one that has *not* been modified.

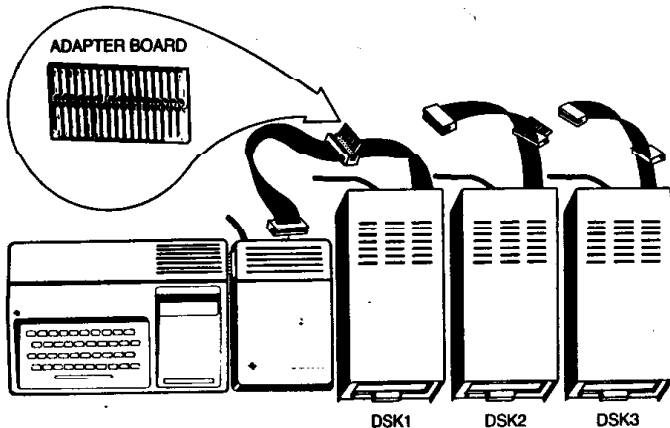

The first drive, the one connected directly to the controller, is identified as DSK1 by TI BASIC. The second drive, connected to the cable of DSK1, is DSK2. The third drive is DSK3. The labels provided with your drive(s) can be used to identify each drive.

Powering Up the System

After the controller and drives have been connected, connect the power to the disk controller, and turn it on with the switch on the front of the unit. Now connect the power to the disk drives, and turn them on with the switch on the rear of each unit.

WARNING

Each time you operate your computer/disk system, follow this power-up sequence:

1. **First turn on the disk controller and disk drives.**
2. **Then turn on the computer console and monitor.**

For proper memory allocation by the computer, the disk controller must be ON when the computer is switched on. Otherwise the disk drives, controller, and Disk Manager module will not function correctly. The computer must be turned off and turned back on in order to restore normal operation.

When you turn on the console, the disk drive working lights may come on briefly and then go off. If they stay on, the disk drive cable is probably plugged in upside down. Turn off all units and make sure that the disk drive cable connection(s) have been made properly.

Note: If you have more than one drive attached, they must all be switched on, even if you plan to use only one.

Do *not* put any diskettes in the drives yet. Go into TI BASIC and enter the following program.

```
100 OPEN #1:"DSK1.X"  
110 CLOSE #1
```

Run the program and observe Drive One (DSK1). Its "working" light should come on as it attempts to read a diskette. The light indicates that the drive is connected properly. If the drive does something else, or does nothing, check all connections and see that all devices have power.

Even though the disk drive is operating, the following message appears on the screen because there is no diskette in the disk drive.

*I/O ERROR 06 IN 100

Repeat the test for Drives Two and Three if you have them, altering the program to reference DSK2 and DSK3, respectively.

Now that you have verified that the disk drives are operating, type **BYE** and press **ENTER**. Then insert the Disk Manager module (supplied with the controller) into the slot on the console. Pressing any key makes the master selection list appear. You now have the option of utilizing your disk system with TI BASIC or with the Disk Manager Command Module (in English, German, or French).

You are ready to start using your disk system as described in the following sections of this manual. If you have problems in operating the disk system, please review the *Service and Warranty* section thoroughly before returning any units for repair.

A QUICK LOOK AT THE DISK SYSTEM

This section describes how you can use the system to initialize a diskette, write a program, save it on the diskette, run the program to write and read information from the diskette, and see the catalog of what is on the diskette.

Make sure that power is supplied to all devices. Turn on the disk system, monitor, and computer. Insert a new diskette in Drive One (DSK1). Plug the Disk Manager Command Module into the computer.

Press any key to proceed. Then press **3** to select the Disk Manager Command Module. After a brief title sequence, the following screen appears.

```
          DISK MANAGER
1 FILE COMMANDS
2 DISK COMMANDS
3 DISK TESTS
4 SET ALL COMMANDS FOR
  SINGLE DISK PROCESSING
```

YOUR CHOICE? 1

The number 1 and the cursor (a small rectangle) alternately flash in the space following the YOUR CHOICE? prompt. Number 1 is the default option. However, you want option 4 because only Drive One is going to be used at this time. Choosing this option speeds up the processes. Enter it by pressing the **4** key and pressing **ENTER**. The screen changes so that what was option 4 now says SINGLE DISK PROCESSING HAS BEEN INITIALIZED.

To select the second option, Disk Commands, press **2** and then press **ENTER**. The following screen appears.

```
          DISK COMMANDS
1 CATALOG DISK
2 BACKUP DISK
3 MODIFY DISK NAME
4 INITIALIZE NEW DISK
```

YOUR CHOICE? 1

Again option number 1 is the preselected default. However, every new diskette must be initialized so that the computer can use it. Initialize the diskette by pressing **4** and then pressing **ENTER**. The following screen appears.

```
INITIALIZE NEW DISK
MASTER DISK (1-3)? 1
DISK NOT INITIALIZED
```

```
NEW DISKNAME? _____
```

The prompt **MASTER DISK (1-3)?** has been answered as 1 because single disk operation has been initialized. You can answer the prompt **NEW DISKNAME?** as you like. Legal diskette names are up to ten characters long, and they cannot contain a period or a blank. Type the name you wish and press **ENTER**.

The prompt **40 TRACKS (Y/N)?** appears next. Your answer depends on the brand or type of diskette you are using. (Most have 40 tracks, but a few only allow 35. When you purchase a diskette, ask your dealer how many tracks it holds.) If you enter **YES** by typing **Y** and then pressing **ENTER** (or just pressing **ENTER** to confirm the **Y** that is already there), the diskette is initialized for 40 tracks. If you enter **NO** by typing **N** and then pressing **ENTER**, the diskette is initialized for 35 tracks.

The message **SCREEN IS COMPLETE PRESS: PROC'D, REDO, BEGIN, OR BACK** appears. If the screen is not right, press **SHIFT R (REDO)** and reenter the correct responses. When the screen is correct, press **SHIFT V (PROC'D)**. The diskette is now initialized, a process that takes a total of about a minute. The message

```
INITIALIZE NEW DISK
WORKING....PLEASE WAIT
```

is on the screen for a moment. Then the message **0< WORKING... PLEASE WAIT** appears, followed by **1<**, and then **2>**. The number **2** is increased by one as each sector is initialized, ending at 359 (or 314).

After the initialization process, the message

```
DSK1 - DISKNAME = diskname
AVAILABLE = 358 USED = 0
```

appears if all sectors are usable. Each sector that is unusable increases the **USED** number by one and decreases the **AVAILABLE** number by one. Now, hold down the **SHIFT** key and press **W (BEGIN)** to return to

the main Disk Manager selection list. Then press **SHIFT Z (BACK)**. When the master computer title screen appears, select **TI BASIC** and enter the following program.

```
100 OPEN #1:"DSK1.FIRSTFILE",RELATIVE,INTERNAL
110 FOR A=1 TO 20
120 PRINT #1:"THIS IS RECORD";A
130 NEXT A
140 INPUT "WHICH RECORD? ":A
150 IF A<1 THEN 200
160 IF A>20 THEN 200
170 INPUT #1,REC A-1:AS,B
180 PRINT AS;B
190 GOTO 140
200 CLOSE #1
```

To save the program on the diskette in Disk Drive One under the name "PROGRAM1", enter **SAVE DSK1.PROGRAM1**. The disk drive "working" light goes on, the diskette spins, and the program is saved on the diskette. Enter **NEW** to remove the program from the computer's memory. Enter **OLD DSK1.PROGRAM1**. The program is loaded into the computer's memory from Disk Drive One. Enter **LIST** to see the program.

Enter **RUN** to run the program. The disk drive "working" light comes on as twenty items are stored. The prompt **WHICH RECORD?** appears. Enter a number from 1 to 20. That record is retrieved and displayed on the screen. You can retrieve the records in any order, as often as you like.

When you are finished, enter **21**. The file is closed and you are back in **TI BASIC**. Enter **BYE (not SHIFT Q)** to leave **BASIC** to ensure that the file is properly closed and no data is lost.

With the master selection list on the screen, select the option for the Disk Manager Command Module. Set the commands for single disk processing as you did before. Again choose option 2, **DISK COMMANDS**. This time choose option 1, **CATALOG DISK**. The following screen appears.

```
CATALOG DISK
MASTER DISK (1-3)? 1
DISKNAME = diskname
WHERE DO YOU WANT LISTING?
1 SCREEN
2 SOLID STATE PRINTER
3 RS232C INTERFACE
4 OTHER
YOUR CHOICE? 1
```

The first prompt, MASTER DISK (1-3)? has already been answered as 1 because single disk operation has been initialized. You want the catalog on the screen, so press ENTER to confirm that choice. The following appears.

```
SCREEN IS COMPLETE
PRESS PROC'D, REDO,
      BEGIN, OR BACK
```

Press SHIFT V (PROC'D) and the following screen appears.

```
DSK1 - DISKNAME = diskname
AVAILABLE= 348  USED= 10
```

FILENAME	SIZE	TYPE	P
FIRSTFILE	8	INT/RX	80
PROGRAM1	2	PROGRAM	

```
WORKING.....PLEASE WAIT.
PRESS
CLEAR TO ABORT COMMAND
```

After the screen, has been filled with all the information, the bottom message is replaced with

```
COMMAND COMPLETED
PRESS: PROC'D, REDO,
      BEGIN, OR BACK
```

On the catalog, the DISKNAME is the name you gave to the diskette. The 348 after AVAILABLE is the number of sectors not used. The 10 after USED is the number of sectors in use. The information below shows that FIRSTFILE is an internal file with a fixed length of 80 bytes taking up 8 sectors and PROGRAM1 is a program file taking up 2 sectors. Since there is nothing under "P," neither of the files is protected from being written over.

To leave the Command Module, press SHIFT W (BEGIN) and then SHIFT Z (BACK).

That completes the quick look at the disk system. The next sections describe in detail all of the capabilities of the Disk Memory System.

DISK MANAGER COMMAND MODULE OPERATION

The Disk Manager Command Module is used to perform operations that are impossible or inconvenient in TI BASIC. The module lets you store, retrieve, or manage files by choosing options and giving answers to prompts on the display screen.

When you have completed all the inputs required on a display, the message

```
PRESS: PROC'D, REDO,
      BEGIN, OR BACK
```

appears. You can then choose what you would like to do.

- PROC'D — Pressing SHIFT V (PROC'D) causes the computer to perform the action that was requested or to repeat the current process.
- REDO — Pressing SHIFT R (REDO) enables you to start again at the top of the current display. This lets you make changes in the answers to your prompts.
- BEGIN — Pressing SHIFT W (BEGIN) takes you back to the main Disk Manager selection list.
- BACK — Pressing SHIFT Z (BACK) takes you back to the previous index (selection list).

(Note: These options are always active when the cursor appears on the screen.)

Some prompts already have an answer in place. These preprogrammed responses (default values) represent common or usual answers to these prompts. If the answer is the one you want, you don't need to type that response. Just press ENTER to confirm it. If you want to give a different response, press the key for the response you want and then press ENTER.

IMPORTANT NOTICE

To leave the Disk Manager Command Module without the chance of losing any programs or data stored on the diskette, follow this procedure:

1. Press SHIFT W (BEGIN) to return to the initial Disk Manager selection index.
2. Then press SHIFT Z (BACK) to leave the module, closing all files.

Editing

If you want to correct a typing error *before* you press **ENTER**, use the editing and cursor-moving keys. Holding down the **SHIFT** key and pressing **←**, move the cursor left to the character you want to change. Retype the correct character(s).

You can erase errors by using the **Space Bar**. Backspace (**SHIFT** **←**) to a point where you want to begin erasing. Then press the **Space Bar** to move the cursor over the characters on the screen. You can also erase a line (*before* pressing **ENTER**) by holding down the **SHIFT** key and pressing **C**.

In certain applications, **SHIFT F** (DELETE) and **SHIFT G** (INSERT) are also active.

After you have pressed **ENTER**, you must press **SHIFT R** (REDO) to change or correct entries.

File Commands

The first command on the main selection list of the Disk Manager module is **FILE COMMANDS**. Choosing this option gives you access to the commands that operate on individual files rather than the entire disk.

The name of a file can be up to ten characters long and can use any characters except the period and the space character. Valid names for files are the same as valid names for diskettes.

When you choose the **FILE COMMANDS** option, the following screen appears.

```
FILE COMMANDS
1 COPY FILE
2 RENAME FILE
3 DELETE FILE
4 MODIFY FILE PROTECTION
```

YOUR CHOICE? 1

COPY FILE — You can copy a file in **TI BASIC** by reading it and then writing it, item by item, to the new file. With the Command Module, you can do the process more simply. When you choose this option, the following screen appears.

```
COPY FILE
MASTER DISK (1-3)? 1
```

Your response to the prompt **MASTER DISK (1-3)?** indicates which disk drive contains the file you are going to copy. When you answer the prompt, the **DISKNAME** is filled in, and the prompt **FILENAME?** appears. Enter the name of the file you wish to copy.

The prompt **COPY DISK (1-3)?** appears. Your answer determines which disk drive will be copied to. When you answer it, the **DISKNAME** is filled in, and the prompt **FILENAME?** appears. Enter the name of the new file.

RENAME FILE — When you choose this option, the following screen appears.

```
RENAME FILE
MASTER DISK (1-3)? 1
```

Your response to the prompt **MASTER DISK (1-3)?** indicates which disk drive contains the file you want to rename. When you answer, the **DISKNAME** is filled in, and the prompt **FILENAME?** appears. Enter the present name of the file. The prompt **NEW FILENAME?** appears. Enter the new name that you want the file to have.

DELETE FILE — With the Command Module, you can not only delete a file, but also go through all the files on a diskette, choosing which ones to delete. When you choose this option, the following screen appears.

```
DELETE FILE
SELECTIVE (Y/N)? N
```

The answer to the prompt **SELECTIVE (Y/N)?** determines whether you delete just one file or go through the diskette choosing which files to delete. If you enter **N**, then you delete just one file. If you enter **Y**, you may select which files you wish to delete.

The prompt **MASTER DISK (1-3)?** appears. Your response indicates which disk drive contains the file(s) you are going to delete. Based on your answer, the **DISKNAME** is filled in. If you have chosen not to be selective, the prompt **FILENAME?** appears. Enter the name of the file you wish to delete.

If you have chosen to be selective, each file on the diskette is presented by name, and you choose whether or not to delete it by answering the prompt DELETE (Y/N)? If a file is protected, and you choose to delete it, the prompt OVERRIDE PROTECTION (Y/N)? appears. If you want to delete the file even though it is marked as protected, enter Y. If you do not wish to delete it, enter N. The computer will return an error message, but you can go on without any difficulty by pressing SHIFT V (PROC'D).

MODIFY FILE PROTECTION — The Command Module enables you to mark a file so that it cannot be written on. This means that a TI BASIC program or data cannot be changed without removing its protection with the Command Module. When you choose this option, the following screen appears.

```
MODIFY FILE PROTECTION
MASTER DISK [1-3]? 1
```

Your response indicates which disk drive contains the file you want to modify. When you answer the prompt, the DISKNAME is filled in. Then, enter the name of the file you wish to alter. The answer to the prompt PROTECT (Y/N)? determines if the file is to be protected from being written on. If you answer Y, it is protected. If you answer N, it is not protected.

If a file is protected, you cannot copy another file over it or rename it with the Command Module. Attempts to perform these operations will cause an error message to appear. In TI BASIC, a protected data file may only be opened for input; it cannot be written to.

Disk Commands

The second option on the main selection list of the Disk Manager module is DISK COMMANDS. Choosing this option gives you access to the commands that involve the entire disk.

```
DISK COMMANDS
1 CATALOG DISK
2 BACKUP DISK
3 MODIFY DISK NAME
4 INITIALIZE NEW DISK
```

```
YOUR CHOICE? 1
```

CATALOG DISK — Choose this option to get a catalog of all the programs and data files on the disk. When you choose it, the following screen appears.

```
CATALOG DISK
MASTER DISK [1-3] 1
```

Choose the disk drive containing the diskette that you want cataloged. As soon as you enter the disk drive number, the diskette's name is filled in, and the following appears.

```
WHERE DO YOU WANT LISTING?
1 SCREEN
2 SOLID STATE PRINTER
3 RS232 INTERFACE
4 OTHER
```

```
YOUR CHOICE? 1
```

If you choose 1, SCREEN, the listing appears on the monitor screen. If there are too many lines to fit on the screen, press and hold the **Space Bar** until the lines stop scrolling. (Press and hold the **Space Bar** once more to start scrolling again.)

If you choose 2, SOLID STATE PRINTER, the entire catalog is printed on the Thermal Printer connected to the computer.

If you choose 3, RS232 INTERFACE, the entire catalog is transferred to the RS232 Interface with default parameters. From there it may go to a line printer, through a modem, or to whatever device is connected to RS232 Interface. See the RS232 Interface Manual for more information on its use.

If you choose 4, OTHER, the prompt DEVICE NAME appears. You may then choose any device and file that you could choose if you were using the TI BASIC command OPEN. For example, you could enter DSK1.CATLIST, and the catalog would be put on the diskette in Disk Drive One under the file name CATLIST.

The catalog list has the following form.

```
DSK1 - DISKNAME= diskname
AVAILABLE= nnn   USED= nnn
FILENAME      SIZE  TYPE  P
-----
AAAAAAAAAA  nnn  PROGRAM
BBBBBBBBBB  nnn  DIS/VARnnn Y
CCCCCCCCC  nnn  DIS/FIXnnn
DDDDDDDDDD  nnn  INT/VARnnn Y
EEEEEEEEEE  nnn  INT/FIXnnn
```

The characters after DISKNAME are the name you gave the diskette. The number shown after AVAILABLE is the number of sectors that are available for use. The number shown after USED is the number of sectors that are being used to store data and programs plus the number of sectors that are not usable. The used and available sectors total 358 (or 313).

The FILENAME is the name of the file, and SIZE is the number of sectors used for the file. TYPE gives the parameters of the file. If a file type is PROGRAM, the file is probably a BASIC program. DIS/VARnnn indicates a DISPLAY format file of VARIABLE length records, with a maximum record length of nnn characters. A file listed as DIS/FIXnnn is a DISPLAY format file of FIXED length records, with a maximum record length of nnn characters. INT/VARnnn designates an INTERNAL format file of VARIABLE length records, with a maximum record length of nnn characters, while a file listed as INT/FIXnnn is an INTERNAL format file of FIXED length records, with a record length of nnn characters. (See *File Processing* in the next section of this manual for an explanation of DISPLAY versus INTERNAL formats and VARIABLE versus FIXED length files.) The "P" column indicates whether or not the file is protected. If a "Y" is present, the file cannot be written on.

BACKUP DISK — You choose this option when you want to make a copy of a diskette. This is usually done so that you have a spare copy of data and programs in case something happens to the original. It is also used to put files in order on a disk. Making a backup copy compresses the information on the diskette to take as little space as possible. (To copy disks if you are using a single disk drive, follow the instructions given on the screen.)

Note: How long the backup takes depends on two things: the number of files on the master diskette and the length of each file. Also, if the copy diskette has not previously been initialized, the initializing process will require approximately one additional minute. As a general rule, it takes about 20 seconds to copy 11.5K bytes of data.

The following describes the backup process when you have two or three drives. When you choose this option, the following display appears.

```
BACKUP DISK
SELECTIVE (Y/N)? N
```

Your response to the prompt SELECTIVE (Y/N)? determines if all the files or only selected files on the diskette are to be copied. If you enter N, all files on the diskette are copied. If you enter Y, you may choose which files you want to copy.

The prompt MASTER DISK (1-3)? appears, requesting the number of the disk drive containing the diskette that is to be copied. When you answer that prompt, the diskette's name is filled in.

The prompt COPY DISK (1-3)? appears. Your response here determines which diskette will have the data copied onto it. If the diskette is initialized, its name is filled in. If it is not initialized, the message DISK NOT INITIALIZED appears. Then the prompt INITIALIZE NEW DISK (Y/N)? appears. Data cannot be copied unless the diskette is initialized. If the diskette is initialized and has data on it, the data there is not erased in the copy process.

If the sectors USED on the master diskette exceed the sectors AVAILABLE on the copy diskette, there will not be enough room on the copy diskette. If you have already started copying, press and hold SHIFT C (CLEAR) to stop the process. Then insert a new copy diskette and start over.

If you choose to initialize the diskette, the prompt DISKNAME? appears. Enter the name you want to use for the new diskette. Then the prompt 40 TRACKS (Y/N)? appears. If the new diskette has 40 tracks, enter Y. If it has 35 tracks, enter N. The message INITIALIZE NEW DISK WORKING.....PLEASE WAIT appears as the diskette is initialized.

After the new diskette is initialized, or if it was already initialized, the copy process continues. If you are copying the entire diskette, the message WORKING.....PLEASE WAIT PRESS: CLEAR TO ABORT COMMAND appears, and information about the copying process appears on the screen as files are copied.

Note: If you need to stop the process, you may have to press and hold SHIFT C (CLEAR) for a few seconds. The Disk Manager module will not stop until it finishes copying the current file. Hold down SHIFT C (CLEAR) until the module responds.

If you are copying only selected files, each file is listed, followed by the prompt COPY FILE (Y/N)? You may choose to copy the file by entering Y or not to copy it by entering N.

On a single disk drive system, the copy procedure consists of reading as much as possible from the first diskette into the computer's memory, removing the first diskette and inserting the second, writing the data from the computer's memory onto the second diskette, removing the second diskette and reinserting the first diskette as prompted, and repeating the process until all data has been copied. The on-screen prompts guide you through the process.

MODIFY NAME — Choose this option when you want to change the name of the diskette. When you choose it, the following screen appears.

```
MODIFY DISK NAME
MASTER DISK (1-3)? 1
```

Your response to the prompt MASTER DISK (1-3)? indicates the disk drive that contains the diskette. The disk name is then filled in and the prompt NEW DISKNAME? appears. Enter the name you want the diskette to have.

INITIALIZE NEW DISK — The first thing that has to be done to a new diskette is to initialize it so that the computer can use it. When you choose this option, the following screen appears.

```
INITIALIZE NEW DISK
MASTER DISK (1-3)? 1
```

Your response to the prompt, MASTER DISK (1-3)? indicates which disk drive holds the diskette. Then the name of the diskette or the message DISK NOT INITIALIZED appears, followed by the prompt NEW DISKNAME? You then type and enter whatever name you want to give the disk. Legal disk names are up to ten characters, not containing a period or a blank.

The prompt 40 TRACKS (Y/N)? appears. If the new diskette has 40 tracks, enter Y. If it has 35 tracks, enter N.

When you press SHIFT V (PROC'D), the diskette is initialized, a process that takes about a minute. The message

```
INITIALIZE NEW DISK
WORKING....PLEASE WAIT
```

is on the screen for a moment. Then the message 0< WORKING.... PLEASE WAIT appears followed by 1<, and then 2>. The number 2 is increased by one as each sector is initialized, ending at 359 (or 314).

Disk Tests

The third option on the Disk Manager selection list is DISK TESTS. It is sometimes necessary to check the condition of a diskette, the disk drive, and the controller. There are two levels of testing that can be done. The first is called a quick test. Each loop takes about two minutes if you choose to make the test destructive and about 40 seconds if you choose to make it non-destructive (information on the disk is preserved). The non-destructive test should satisfy most requirements. The destructive version of the test should normally be done to new diskettes to determine whether or not they are good.

The second test is a comprehensive test that runs an exhaustive check on the diskette, controller, and disk drive. In the process, it destroys all the data that was on the diskette. Before running this test, you should make a backup copy of the diskette if you want to retain the data, or you can run the test on a blank diskette. The comprehensive test takes about 16 minutes for each loop.

Note: After a diskette has been put through a destructive test, it must be initialized before it can be reused. Also, if a diagnostic test reports an error condition, repeat the test with a known good diskette to verify that the disk system is at fault.

When you choose DISK TESTS, the following screen appears.

```
DISK TESTS
1 QUICK TEST
2 COMPREHENSIVE TEST
```

```
YOUR CHOICE? 1
```

If you choose 1, QUICK TEST, the following screen appears.

```
QUICK TEST
DESTRUCTIVE TEST (Y/N)? N
```

The prompt DESTRUCTIVE TEST (Y/N)? allows you to control whether or not the data on the disk is destroyed. If you want it destroyed, answer Y. If you do not want it destroyed, answer N.

The prompt, MASTER DISK (1-3)? appears. Your response indicates which disk drive holds the diskette you want to test. When you answer, the DISKNAME is filled in, and the prompt 40 TRACKS (Y/N)? appears if you selected DESTRUCTIVE TEST. If you answer Y, the diskette is tested for 40 tracks. If you answer N, it is tested for 35 tracks. Next, the prompt LOOP (Y/N)? appears. It determines whether the test is to be run once or over and over until you stop it. Answer Y if you want it to be run repeatedly. Answer N if you want it to be run just once.

The prompt LOG ERRORS? (Y/N)? appears. Your answer determines whether or not any errors found are to be recorded on another device in addition to being shown on the screen. If you do not want any other record, enter N. If you want a record somewhere else, enter Y. If you enter Y, the prompt DEVICE NAME? appears. You may then enter the device and file name to which you want the log to go. For example, if you want a record put on the diskette in Drive Two under the file name LOGLIST, enter DSK2.LOGLIST. If you want the logged errors printed on an attached Solid State Thermal Printer, enter TP as the device name. Note that you cannot log to the disk drive that is being tested.

When the test is run, the record of any errors looks like this:

```
BAD ADDRESS/CODE   nnn/nn
TOTAL ERRORS:     nn
COMPLETED PASS:  m
```

```
WORKING..... PLEASE WAIT.
PRESS
CLEAR TO ABORT COMMAND
```

The first number after BAD ADDRESS/CODE indicates the sector that was found to be bad. The second number is the error code for the error that was found. (See Appendix B.) An error tone is generated for each error found.

The number after TOTAL ERRORS: is the total number of errors that have been found so far in the diskette. The number after COMPLETED PASS: is the number of times the test has been run. If you have chosen not to have the test loop, then only one pass is made. Otherwise this test shows how many loops have been run so far.

If you choose to run the comprehensive test, the following screen appears.

```
COMPREHENSIVE TEST
DESTRUCTIVE
MASTER DISK (1-3)? 1
```

Note: This test takes about 16 minutes to complete. All data and/or programs on the diskette will be lost.

From this point on, the procedure is the same as for the Quick Test. Just respond to the prompts as they appear on the display.

The Comprehensive Test consists of six tests that write to and read from all of the sectors on the diskette.

Single Disk Processing

Option 4 on the main selection list of the Disk Manager module is SET ALL COMMANDS FOR SINGLE DISK PROCESSING. Choose this option if you only have one disk drive or if you are only going to be using DSK1. This option speeds up the processes that the Command Module performs. After you choose this option, the message SINGLE DISK PROCESSING HAS BEEN INITIALIZED appears on the screen. (You may go back to multiple disk operations only by leaving the module and reentering it.)

Be sure to insert a diskette into the disk drive before selecting any other commands. The prompts MASTER DISK(1-3)? and COPY DISK(1-3)? will automatically be answered each time you choose an option, and the disk will be accessed immediately.

DISK SYSTEM OPERATION WITH TI BASIC

Your disk memory system can be used conveniently with TI BASIC. This section discusses saving/loading programs and processing file data with programs.

The disk system requires some working space in the main memory (RAM) of the Home Computer. The exact amount of space required depends on the number of files which are allowed to be open at any given time. In TI BASIC this number is preset to 3. The disk system then uses 2088 bytes of RAM.

You may use the CALL FILES statement to change the number of files that may be open. Keep in mind, however, that increasing the number of allowable open files also increases the amount of memory used by the disk system. (See CALL FILES for more information.)

Saving and Loading Programs

The disk system stores and retrieves TI BASIC programs quickly and efficiently. Approximately 100 fifty-line programs can be stored on a single diskette.

The SAVE command is used to store a program on the diskette. The format is

SAVE *device.program-name*

The *device* is DSK1, DSK2, or DSK3, depending on which disk drive you want to address. The *program-name* is any valid identifying name you want to give your program. Valid program names can be up to ten characters long and can include any character except the period and the space characters.

For example, to store a program called COLORDEMO on the diskette in Drive One, you would enter this command (with the program in memory):

SAVE DSK1.COLORDEMO

Alternatively, the diskette's name can be specified, rather than the number of the disk drive. To store a program called COLORDEMO on a diskette named MYDISK, you enter

SAVE DSK.MYDISK.COLORDEMO

The computer searches all attached drives until it finds the one that contains the diskette named MYDISK.

The OLD command is used to read a program from a diskette. The format is

OLD *device.program-name*

When you enter the OLD command, the program you designate by name is read into the computer's memory. You can then RUN it, LIST it, or EDIT it — just as you would use a program entered from the keyboard.

File Naming Conventions

The name of a file can be up to ten characters long, and may use any characters except the period and the space characters. Valid names for files are the same as valid names for diskettes.

File Processing

There are seven main TI BASIC statements that are used to access files on diskettes. They are OPEN, CLOSE, INPUT, PRINT, EOF, RESTORE, and DELETE. In addition, a special subprogram named CALL FILES allows you to change the number of files allowed to be opened at the same time. The following discussions of each of these statements relate to their use with the disk system.

OPEN — The OPEN statement prepares a TI BASIC program to use data files stored on diskettes. It provides a link between a file-number used in a program and the file on the diskette, and it describes a file's characteristics so that a program can process or create the file. If the file already exists, the description that is given in the program must match the actual characteristics of the file.

The OPEN statement has the following general form:

```
OPEN #file-number:"device.file-name" [file-
organization] [file-type] [open-mode] [record-type]
```

The *file-number* and *device.file-name* must be included in the OPEN statement. The other information may be in any order, or may be omitted. If an item is omitted, the computer assumes certain defaults, which are described below.

- *file-number* — The *file-number* (1 through 255) is assigned to a particular file by the OPEN statement. (File number 0 is the keyboard and screen of the computer. It cannot be used for other files and is always open.) You may assign file numbers as you wish, with each file having a different number.

The *file-number* is entered as a number sign (#) followed by a numeric expression that, when rounded to the nearest integer, is a number from 1 to 255, and is not the number of a file that is already open.

- *device.file-name* — The *device* refers to the diskette on which a particular file is stored. If a file is on a diskette in Disk Drive One, the device is DSK1. For Drive Two, the device is DSK2. For Drive Three, the device is DSK3. The *file-name* may be any valid file name.

Instead of the disk drive number you may use DSK, followed by the diskette name, a period, and then the *file-name*.

```
OPEN#1:"DSK.DISKETTE.FILE1"
```

The computer will search all drives for the diskette with the name you give.

- *file-organization* — Files can be organized either sequentially or randomly. Records in a sequential file are read or written one after the other. Records on random files can be read or written in any order. They may also be processed sequentially.

To indicate which structure the file has, enter either SEQUENTIAL for sequential files or RELATIVE for random files. You may optionally specify the initial number of records on a file by following the word SEQUENTIAL or RELATIVE with a numeric expression. If you do not specify the *file-organization*, the default is SEQUENTIAL.

For processing files in order, SEQUENTIAL files are usually processed more quickly than RELATIVE files. But in some uses, random files are more efficient.

-
- *file-type* — Files can be stored on diskettes either in easily readable ASCII characters or in machine-readable binary form. If the information is going to be printed or displayed for people to use, ASCII format is usually a better choice. However, binary records take up less space and are processed more quickly by the computer.

To specify that you wish the file to be in ASCII format, enter DISPLAY. (The length of a DISPLAY-type record is limited to about 150 bytes.) To specify binary format, enter INTERNAL. If you do not specify a *file-type*, the default is DISPLAY.

- *open-mode* — This entry instructs the computer that the file may be both read and written upon (UPDATE), that it may only be read (INPUT), that it may only be written to (OUTPUT), or that it may only be added to (APPEND).

If a file is marked as protected, it cannot be written to and may only be opened for input. Also, APPEND mode can only be specified for VARIABLE length records. If you do not specify an *open-mode*, the computer assumes the default UPDATE.

Note: If an unprotected file already exists on a diskette, specifying an *open-mode* of OUTPUT to the same file name writes over the existing file with the new file. You can prevent this by reading all the existing records so that you move to the end of the file or by using the RESTORE statement with the proper record.

- *record-type* — File records may be all the same length (FIXED) or may vary in length (VARIABLE). If they are all the same length, any that are shorter are padded to make up the difference. Any that are longer may be truncated to the proper length. Files that have FIXED-length records are processed faster than files with VARIABLE-length records.

If you like, you may specify a maximum length of a record by following VARIABLE or FIXED with a numeric expression. The maximum length for a VARIABLE file is 254 bytes, and the maximum for a FIXED file is 255 bytes. If you do not specify a record length, the default is 80.

RELATIVE files must have FIXED length records. If you do not specify a *record-type* for a RELATIVE file, the default is FIXED.

SEQUENTIAL files may be either FIXED or VARIABLE. If you do not specify a *record-type* for a SEQUENTIAL file, the default is VARIABLE. A FIXED-length file may be reopened for either SEQUENTIAL or RELATIVE access independent of previous *file-organization* assignments.

The following are examples of OPEN statements.

OPEN #1: "DSK1.MYFILE" Creates or reopens a file on the diskette in Drive One with a name of MYFILE. The file is SEQUENTIAL, kept in DISPLAY format, in UPDATE mode with VARIABLE length records with a maximum length of 80 bytes. (These are the default attributes assigned by the computer.)

OPEN #23: "DSK.MYDISK.X".RELATIVE 100,INTERNAL,OUTPUT,FIXED 80 Creates or reopens a file named X on the diskette named MYDISK in whichever drive it is located. The file is RELATIVE, kept in INTERNAL format, in OUTPUT mode with FIXED length records with a maximum length of 80 bytes. Initially, 100 records are made available for the file.

OPEN #243: A\$,INTERNAL If A\$ equals DSK2.ABCD, creates or reopens a file on the diskette in Drive Two with a name of ABCD. The file is SEQUENTIAL, kept in INTERNAL format, in UPDATE mode with VARIABLE length records with a maximum length of 80 bytes.

CLOSE — The CLOSE statement discontinues the association between a file and a program. After the CLOSE statement is performed, the file is not available unless it is opened again with an OPEN statement. Files may optionally be deleted by adding :DELETE to the end of the CLOSE statement.

The CLOSE statement has the following general form:

CLOSE #file number [:DELETE]

The *file-number* is the number which you used in the OPEN statement to open the file.

If you do not close a file, data on it may be lost. If a program ends due to a BREAK statement, due to pressing **SHIFT C** (CLEAR), or because of an error, files may not be closed even if you have a CLOSE statement in the program. However, you can close the files properly by entering **NEW**, or **BYE** if you wish to leave BASIC. Editing the program also automatically closes any open files.

Note: If you leave TI BASIC by pressing **SHIFT Q** (QUIT), data may be lost. Leave TI BASIC *only* by entering **BYE** when you are processing files.

INPUT — The INPUT statement, used with diskettes, allows you to read data from files. It can only be used with files opened in INPUT or UPDATE mode.

The INPUT statement has the following general form:

INPUT #file-number [,REC record-number] :variable-list

The *file-number* and a *variable-list* must be included in the INPUT statement. The *record-number* may optionally be included when reading random-access files.

- *file-number* — The *file-number* is the number assigned to a particular file by the OPEN statement. The *file-number* is entered as a number sign (#) followed by a numeric expression that, when rounded to the nearest integer, is a number from 1 to 255 and is the number of a file that is open.
- *record-number* — A *record-number* refers to the record on the file which you want to read. The *record-number* can only be specified for RELATIVE files. (SEQUENTIAL files are read in sequential order.)
- *variable-list* — The *variable-list* is the list of variables into which you want the data from the file to be read. It consists of string or numeric variables separated by commas.

The following are examples of INPUT statements.

INPUT #1:X\$	Puts into X\$ the next value available in the file that was opened as #1.
INPUT #23:X,A,LL\$	Puts into X, A, and LL\$ the next three values from the file that was opened as #23.
INPUT #11, REC 44:TAX	Puts into TAX the first value of record number 44 of the file that was opened as #11.
INPUT #3:A,B,C,	Puts into A, B, and C the next three values from the file that was opened as #3. The comma after C creates a pending input condition. When the next INPUT statement using this file is performed, one of the following actions occurs: If the next INPUT statement has no REC clause, the computer uses the data beginning where the previous INPUT statement stopped. If the next INPUT statement includes a REC clause, the computer terminates the pending input condition and reads the specified record.

PRINT — The PRINT statement allows you to write data onto files on diskettes. It can only be used with files opened in OUTPUT, UPDATE, or APPEND mode.

The PRINT statement has the following general form:

PRINT #file-number [,REC record-number] [:print-list]

The file-number must be included in the PRINT statement. The record-number may optionally be included when writing to random-access (RELATIVE) files. The print-list is also optional.

- *file-number* — The file-number is the number assigned to a particular file by the OPEN statement. The file-number is entered as a number sign (#) followed by a numeric expression that, when rounded to the nearest integer, is a number from 1 to 255 and is the number of a file that is open.
- *record-number* — A record-number refers to the record on the file which you want to write. The record-number can only be specified for random files (RELATIVE).
- *print-list* — The print-list is the list of values that you want to put on the file. It consists of string or numeric variables or constants separated by commas, colons, and semicolons.

The following are examples of PRINT statements.

PRINT #1:X\$	Puts the value of X\$ into the next position of the file that was opened as #1
PRINT #23:X:A;"TIMES 4"	Puts the value of X, A, and "TIMES 4" into the next record in the file that was opened as #23.
PRINT #11,REC 44:"TAX"	Puts the string constant "TAX" into record number 44 of the file that was opened as #11.
PRINT #3:A,B,C,	Puts the values of A, B, and C into the next three positions in the file that was opened as #3. The comma after C creates a pending print condition. When the next PRINT statement is performed, one of the following actions occurs: If the next PRINT statement has no REC clause, the computer places the data immediately following the previous data. If the next PRINT statement has a REC clause, the computer writes the pending print record onto the file at the position indicated by the internal counter and performs the new PRINT-REC statement as usual.

EOF — The EOF (end-of-file) function indicates whether there is another record to be read from a file. The EOF function has the following general form:

EOF(*file-number*)

The value of *file-number* must correspond to the number of an open file.

The EOF function always assumes that the next record is going to be read sequentially, even if you are using a RELATIVE file.

The value returned by the EOF function depends on where you are in the file. If you are not at the end of the file, the value returned is 0. If you are at the end of the file, the function returns a value of 1. If the diskette is full and you are at the end of the file, the function returns a value of -1.

The following are examples of the EOF function.

PRINT EOF(3)	Prints a value of 0, 1, or -1, according to whether you are at the end of the file that was opened as #3.
IF EOF(27)<>0 THEN 1150	If you are at the end of the file that was opened as #27, control is transferred to line 1150.

The usual way to keep track of the last record in RELATIVE files is to maintain a "dummy" record as the first record in the file. This record contains the number of records in the file. Each time you change the length of the file, you must update this record.

RESTORE — The RESTORE statement is used to position you at a specified record on a file. The statement has the following general form:

RESTORE *#file-number* [,REC *record-number*]

The *file-number* must be included in the RESTORE statement when it is used with files. The *record-number* may optionally be included.

■ *file-number* — The *file-number* is the number assigned to a particular file by the OPEN statement. The *file-number* is entered as a number sign (#) followed by the number of an open file.

■ *record-number* — A *record-number* refers to the record on the file, where you want the file positioned.

The following are examples of the RESTORE statement.

RESTORE #6	Causes the next record read from or written to the file that was opened as #6 to be the first record on the file.
RESTORE #23,REC 12	Causes the next record read from or written to the file that was opened as #23 to be the thirteenth record on the file (remember that the first record is number zero).

With RELATIVE files you usually only use RESTORE to position the file so that you can use the EOF function, because the record that you want to read or write can be specified in the INPUT or PRINT statement.

DELETE — The DELETE statement is used to delete files. It has the following general form:

DELETE *#file-number*

The *file-number* must be included in the DELETE statement. The *file-number* is entered as a number sign (#) followed by a numeric expression that, when rounded to the nearest integer, is a number from 1 to 255 and is the number of a file that is already open.

Note: Files can only be deleted if they are not protected.

CALL FILES — The FILES subprogram is used to change the number of files (a maximum of nine) that can be OPEN at the same time. (The default number of allowable OPEN files in TI BASIC is three.) The amount of memory (RAM) available for programs is reduced by 534 bytes for the Disk Controller, plus 518 more bytes for each allowable OPEN file. Therefore, CALL FILES(1) gives you more memory space for your program but allows only one OPEN file.

The CALL FILES command has the following general form:

```
CALL FILES(number)
NEW
```

The *number* must be a single digit from 1 through 9. It is the number of files that can be OPEN at the same time. The command NEW must be made immediately following the CALL FILES command. If CALL FILES is not executed, the default number of files that can be OPEN is 3.

CAUTION

CALL FILES can only be used as a command in TI BASIC. It must not be used as a statement in a TI BASIC program. Using CALL FILES in a program or not following it with NEW can cause unpredictable results, including loss of a program and/or loss of data on a diskette.

Cataloging Files

By accessing the file index on a diskette, you can use TI BASIC to read a catalog of disk contents. The diskette-index (or catalog) file is an unnamed, INTERNAL-format, FIXED-length file. The following is an example of an OPEN statement that accesses the catalog on Drive One:

```
100 OPEN #1:"DSK1:","INPUT,RELATIVE,INTERNAL
```

Note: File-name is omitted, since the catalog is an unnamed file.

Every record in the catalog file contains four items: one string and three numeric values, written in INTERNAL format. There are exactly 128 records in the file, numbered from 0 through 127.

Record #0 contains information about the diskette. The string (up to ten characters in length) indicates the name of the diskette, and the numerical items give the following information:

- the record type (always a zero for record #0)
- the total number of sectors on the diskette (358 or 313)
- the number of available sectors on the diskette

Records 1 through 127 contain information about the corresponding files in the index. The string item is the file name, and the numeric items are as follows:

- The file type (a negative value if the file is protected)
 - 1 = DISPLAY/FIXED data file
 - 2 = DISPLAY/VARIABLE data file
 - 3 = INTERNAL/FIXED data file
 - 4 = INTERNAL/VARIABLE data file
 - 5 = BASIC program or other "memory image" data
- The total number of sectors allocated for the file
- The total number of bytes per record

A type-5 file always has a zero (0) as the number of bytes per record, since this measurement does not relate to memory image data.

A sample program listed at the end of this section illustrates how to display a diskette catalog.

Sample Programs

Three programs are included in this section. The first illustrates some of the techniques that can be used for file management, showing how to open a file, write records randomly to it, and read records randomly from it. The second program shows how to save the contents of the screen on a file and put it back on the screen later. This is useful if you have created a graphics screen and want to be able to store and retrieve it. The third program shows how to read the catalog from a diskette using TI BASIC.

GENERAL PROGRAM — The following program shows general file handling techniques for a random-access file.

The first section, lines 100 through 130, gives the entry instructions.

```
100 CALL CLEAR
110 OPEN #10:"DSK1:GENFILE",RELATIVE 50,INTERNAL
120 PRINT "ENTER 'XXX' TO LEAVE ENTRY."
130 PRINT
```

The next section, lines 140 through 220, allows entry of up to 50 records, numbered 0 through 49. Line 180 checks to see if the last record has been entered. If 50 records have been entered, line 220 informs the user that the file is full.

```
140 REM ENTRY
150 FOR RECORD1 = 0 TO 49
160 PRINT "RECORD"; RECORD1;
170 INPUT XS
180 IF XS = "XXX" THEN 230
190 PRINT #10,REC RECORD1;XS
200 NEXT RECORD1
210 REM FULL
220 PRINT "FILE FULL"
```

The next section, lines 230 through 370, allows the program user to choose what he would like to do.

```
230 REM CONTROL SECTION
240 PRINT
250 PRINT "ENTER 'S' TO PRINT FILE"
260 PRINT "SEQUENTIALLY"
270 PRINT "ENTER 'C' TO CHANGE OR ADD"
280 PRINT "A RECORD."
290 PRINT "ENTER 'R' TO PRINT A RECORD."
300 PRINT "ENTER 'L' TO LEAVE THE"
310 PRINT "PROGRAM."
320 INPUT "YOUR CHOICE: ";YS
330 PRINT
340 IF YS = "S" THEN 440
350 IF YS = "C" THEN 530
360 IF YS = "L" THEN 630
370 IF YS <> "R" THEN 230
```

The next section, lines 380 through 430, prints a specific record. Line 400 checks to see that the record chosen exists.

```
380 REM PRINT A RECORD
390 INPUT "WHICH RECORD? ";RECORD2
400 IF RECORD2 > RECORD1 - 1 THEN 610
410 INPUT #10,REC RECORD2;XS
420 PRINT "RECORD";RECORD2;"IS ";XS
430 GOTO 230
```

The next section, lines 440 through 520, prints the entire file in sequential order.

```
440 REM SEQUENTIAL
450 PRINT "THE FOLLOWING ARE THE"
460 PRINT "RECORDS:"
470 RESTORE #10
480 FOR RECORD2 = 0 TO RECORD1 - 1
490 INPUT #10;XS
500 PRINT RECORD2;XS
510 NEXT RECORD2
520 GOTO 230
```

The next section, lines 530 through 620, allows a record to be changed or added. Line 550 checks to see that the line to be changed or added is not beyond the end of the current file.

```
530 REM CHANGE A RECORD
540 INPUT "WHICH RECORD? ";RECORD2
550 IF RECORD2 > RECORD1 THEN 610
560 INPUT "NEW VALUE? ";XS
570 PRINT #10,REC RECORD2;XS
580 IF RECORD2 < RECORD1 THEN 230
590 RECORD1 = RECORD2 + 1
600 GOTO 230
610 PRINT "RECORD IS BEYOND THE END OF THE FILE."
620 GOTO 230
```

The last section, line 630, closes the file at the end of the program.

```
630 CLOSE #10
```

SAVE AND RESTORE A SCREEN — Lines 100 through 210 of the following program can be used as a subroutine in other programs when you want to save something you've created on the screen. (Be sure that you change the file name each time you use the program so that you don't write over a file that you have previously saved.) This program only saves and restores the characters that are on the screen. Information about redefined characters and colors is not saved.

```

100 REM SAVE A SCREEN
110 REM ADD AT END OF THE PROGRAM THAT PRODUCES THE
SCREEN
120 REM
130 REM CHOOSE A UNIQUE FILENAME
140 OPEN #20:"device.file-name",INTERNAL
150 FOR ROW = 1 TO 24
160 FOR COLUMN = 1 TO 32
170 CALL GCHAR(ROW,COLUMN,X)
180 PRINT #20:X
190 NEXT COLUMN
200 NEXT ROW
210 CLOSE #20

```

Lines 220 through 330 can be run as an independent program. They recall the contents of a screen that has been previously saved and put them on the screen.

```

220 REM REPRODUCE A SCREEN
230 OPEN #30:"device.file-name",INTERNAL
240 FOR ROW = 1 TO 24
250 FOR COLUMN = 1 TO 32
260 INPUT #30:X
270 CALL VCHAR(ROW,COLUMN,X)
280 NEXT COLUMN
290 NEXT ROW
300 CLOSE #30
310 REM DELAY TO GIVE TIME TO LOOK AT THE SCREEN
320 FOR DELAY = 1 TO 10000
330 NEXT DELAY

```

READ THE CATALOG — The following program enables you to read and print the catalog for a diskette from TI BASIC. Lines 100 through 160 set up a single-dimension array of five items corresponding to the five types of files. The next four lines ask for the number of the drive containing the diskette you want to catalog and then check to be sure you've made a valid entry.

```

100 CALL CLEAR
110 DIM TYPE$(5)
120 TYPE$(1) = "DIS/RX"
130 TYPE$(2) = "DIS/VAR"
140 TYPE$(3) = "INT/RX"
150 TYPE$(4) = "INT/VAR"
160 TYPE$(5) = "PROGRAM"
170 INPUT "MASTER DISK [1-3]? ":A
180 A = INT(A)
190 IF A < 1 THEN 170
200 IF A > 3 THEN 170

```

The next section opens the file, reads the diskette information for record #0, and displays it on the screen.

```

210 OPEN #1:"DSK"&STR$(A)&".",INPUT,
RELATIVE,INTERNAL
220 INPUT #1:AS,J,J,K
230 DISPLAY "DSK";STR$(A);" - DISKNAME = ";
AS;"AVAILABLE = ";K;"USED = ";J-K

```

The remainder of the program reads the remaining information in the index, formats it, and displays the catalog on the screen.

```

240 DISPLAY "FILENAME SIZE TYPE P":
"-----";
250 FOR LOOP = 1 TO 127
260 INPUT #1:AS,A,J,K
270 IF LEN(AS) = 0 THEN 350
280 DISPLAY AS;TAB(12);J;TAB(17);
TYPE$(ABS(A));
290 IF ABS(A) = 5 THEN 320
300 BS = " " & STR$(K)
310 DISPLAY SEG$(BS,LEN(BS) - 2,3);
320 IF A > 0 THEN 340
330 DISPLAY TAB(28); " ";
340 NEXT LOOP
350 CLOSE #1

```

Appendix A

ERROR CODES IN TI BASIC

The normal error codes for your computer are given in the *User's Reference Guide*. The following codes are for errors that relate to the disk system.

Error codes are two digit numbers. The first digit indicates the command or statement involved in the error, and the second digit tells you the type of error.

**FIRST
DIGIT COMMAND OR STATEMENT**

- 0 OPEN
- 1 CLOSE
- 2 INPUT
- 3 PRINT
- 4 RESTORE
- 5 OLD
- 6 SAVE
- 7 DELETE
- 9 EOF

**SECOND
DIGIT TYPE OF ERROR**

- 0 The disk drive specified could not be found.
- 1 **DEVICE or FILE WRITE PROTECTED** — unprotect the disk by removing the tape from the write-protect slot, or remove protection via the Disk Manager module.
- 2 **BAD OPEN ATTRIBUTE** — one or more OPEN options were illegal or didn't match the file's actual characteristics.

- 3 **ILLEGAL OPERATION** — should not be generated by the disk system. It could be caused, however, by attempting to perform some illegal file operation, such as requesting INPUT from the Thermal Printer.
- 4 **OUT OF SPACE** — The diskette is full, or you are trying to open more files than are allowed.
- 5 **ATTEMPT TO READ PAST END OF FILE.**
- 6 **DEVICE ERROR** — may occur if the diskette is not initialized or is damaged. It may also occur if the system had its power disconnected during a previous print, the disk drive unit is not functioning properly, etc.
- 7 **FILE ERROR** — the indicated file or diskette doesn't exist or you are trying to read a BASIC file as if it were data.

Appendix B

ERROR CODES IN THE DISK MANAGER COMMAND MODULE

If an error code occurs while you are using the Disk Manager Command Module, the error codes may have different meanings from those listed in *Appendix A*.

OPEN errors — An error in an OPEN statement will generate an error code from 00 to 07, and the meanings correspond to those listed under SECOND DIGIT in *Appendix A*.

The following tables explain the meanings of the remaining two-digit error codes.

FIRST DIGIT	TYPE OF ERROR
1	OTHER
2	SEEK OR STEP
3	INPUT
4	PRINT
(5 through 8 are not used.)	
9	SPECIAL ERROR CODE FOR COMPREHENSIVE TEST

SECOND DIGIT	TYPE OF ERROR
1	RECORD NOT FOUND
2	CRC
3	LOST DATA
4	WRITE PROTECTED
5	WRITE FAULT
6	NO DISK/DRIVE or DRIVE NOT READY
7	INVALID INPUT PARAMETERS
(8 is not used.)	
9	SPECIAL ERROR CODE FOR COMPREHENSIVE TEST

The following examples demonstrate several typical error codes and their interpretations.

ERROR CODE	MEANING
16	NO DISK or NO DRIVE
17	INVALID INPUT PARAMETERS
21	SEEK ERROR
31	RECORD NOT FOUND ON INPUT
32	CRC ERROR ON INPUT
33	LOST DATA ON INPUT
41	RECORD NOT FOUND ON PRINT
42	CRC ERROR ON PRINT (ID FIELD)
43	LOST DATA ON PRINT
44	WRITE PROTECTED
99	COMPREHENSIVE TEST DATA WRITTEN ON TEST 5 COULD NOT BE VERIFIED DURING TEST 6

Appendix C

DISKETTE/CASSETTE OPERATIONS

Transfer Programs Between Cassettes and Diskettes

To transfer programs between cassettes and diskettes, load the program into the computer's memory using the OLD command. Then save the program using SAVE.

For example, the following sequence transfers a program from a cassette to the diskette in Disk Drive One and assigns BRYAN as the program file name.

```
OLD CS1
```

(follow normal cassette instructions)

```
SAVE DSK1.BRYAN
```

The data is now on the diskette in Drive One under the name "BRYAN".

The following sequence transfers a program named "EDGIN" from the diskette in Disk Drive One to a cassette.

```
OLD DSK1.EDGIN  
SAVE CS1
```

(follow normal cassette instructions)

The program is now on the cassette.

Transfer Data from Cassette to Diskette

To transfer data from a cassette to a diskette, you must read it from the cassette into the computer and then store it on the diskette. You should first decide how you are going to store the data on the diskette, that is, what parameters you are going to use in the OPEN statement.

The following program transfers data from a cassette to a file named KAY on Disk Drive One. The file is set up in default format.

```
100 OPEN #50:"CS1",INPUT,FIXED  
110 OPEN #60:"DSK1 KAY"  
120 INPUT #50:XS  
130 REM WHEN THE FILE ENDS, THE  
PROGRAM WILL HAVE AN ERROR  
140 PRINT #60:XS  
150 GOTO 120
```

When you run the program, you will be instructed how to use the cassette.

The EOF function cannot be used with cassettes. After you run the program, it ends with error 33, because the cassette runs out of data. **YOU MUST LEAVE BASIC BY ENTERING "BYE"**. If you leave with **SHIFT Q (QUIT)**, data may be lost from the diskette.

SERVICE AND WARRANTY INFORMATION

In Case of Difficulty

If the disk system does not appear to be working properly, check the following:

1. **Power** — Be sure all devices are plugged in. Then turn on the power to the units in the proper sequence: disk drives and controller first, followed by the console and monitor.
2. **Connector Separation** — Check for proper alignment of the console and the controller (they should be parallel).
3. **Cable** — Check that the proper cables are being used. Check the cables for loose or broken leads. Check to see that the cables are properly connected, right side up.
4. **Software** — Be sure all commands and statements are used as described in this manual. If the disk system works properly with the Disk Manager Command Module but not with a program, the problem is probably with the program. Especially check the use of OPEN, INPUT, and PRINT.
5. **Diagnostic Tests** — Check that the diskette, controller, and disk drives are working properly by running the diagnostic tests.
6. **Home Computer** — Check to see that the Home Computer works properly with all accessories disconnected.
7. If none of the above procedures corrects the difficulty, consult "If You Have Questions or Need Assistance" or see the "Service Information" portion of the *User's Reference Guide*.

Diskette Failure Indicators

Diskettes can lose information because of a scratch on their surface. The information lost depends on the shape of the scratch. A circular scratch, probably caused by something being ground into the diskette by the magnetic head, may destroy an entire track, usually losing data from one file.

A straight scratch, such as one made by a pencil or fingernail being run across the exposed area of the diskette, may destroy all the information on a number of sectors. This usually causes information to be lost from most of the files on the diskette. If the scratch goes through sector 0 or 1, all contents of the diskette are lost, since those sectors hold the catalog which the computer uses to find files.

Scratches too small to be visible to the naked eye can cause information to be lost.

Information can also be lost due to exposing diskettes to magnetic fields or excessive heat or cold and by bending or striking them.

Exchange Centers (Local Service Options)

If some part of your disk system requires service, instead of returning it to a service facility for repair or replacement, you may elect to exchange it for a factory reconditioned unit by going in person to one of the exchange centers which has been established across the United States. **A handling fee will be charged by the exchange center for in-warranty exchanges.** Out-of-warranty exchanges will be charged at the rates in effect at the time of the exchange. Please refer to the enclosed Exchange Service listing or call the Consumer Relations Department for exchange fee information and the location of the nearest exchange center.

If You Have Questions or Need Assistance

If you have questions concerning disk system repair or peripheral, accessory, or software purchase, please call our Consumer Relations Department at 800-858-4565 (toll free within the contiguous United States except Texas) or 800-692-4279 within Texas. The operators at these numbers cannot provide technical assistance.

For technical questions about programming, specific applications, etc., you can call 806-741-2663. Please note that this is not a toll-free number, and collect calls cannot be accepted.

As an alternative, you can write to:

Consumer Relations Department
Texas Instruments Incorporated
P.O. Box 53
Lubbock, Texas 79408

Because of the number of suggestions which come to Texas Instruments from many sources containing both new and old ideas, Texas Instruments will consider such suggestions only if they are freely given to Texas Instruments. It is the policy of Texas Instruments to refuse to receive any suggestions in confidence. Therefore, if you wish to share your suggestions with Texas Instruments, or if you wish us to review any BASIC language program which you have developed, please include the following statement in your letter:

"All of the information forwarded herewith is presented to Texas Instruments on a nonconfidential, nonobligatory basis; no relationship, confidential or otherwise, expressed or implied, is established with Texas Instruments by this presentation. Texas Instruments may use, copyright, distribute, publish, reproduce, or dispose of the information in any way without compensation to me."

THREE-MONTH LIMITED WARRANTY

THIS TEXAS INSTRUMENTS DISK CONTROLLER AND DISK MANAGER MODULE WARRANTY EXTENDS TO THE ORIGINAL CONSUMER PURCHASER OF THE ACCESSORY.

WARRANTY DURATION

This Disk Controller and Disk Manager Command Module are warranted for a period of three (3) months from the date of original purchase by the consumer.

WARRANTY COVERAGE

This Disk Controller and Disk Manager Command Module are warranted against defective materials or workmanship. **THIS WARRANTY IS VOID IF THE ACCESSORY HAS BEEN DAMAGED BY ACCIDENT, UNREASONABLE USE, NEGLIGENCE, IMPROPER SERVICE OR OTHER CAUSES NOT ARISING OUT OF DEFECTS IN MATERIALS OR WORKMANSHIP.**

WARRANTY DISCLAIMERS

ANY IMPLIED WARRANTIES ARISING OUT OF THIS SALE, INCLUDING BUT NOT LIMITED TO THE IMPLIED WARRANTIES OF MERCHANTABILITY AND FITNESS FOR A PARTICULAR PURPOSE, ARE LIMITED IN DURATION TO THE ABOVE THREE-MONTH PERIOD. TEXAS INSTRUMENTS SHALL NOT BE LIABLE FOR LOSS OF USE OF THE DISK SYSTEM OR OTHER INCIDENTAL OR CONSEQUENTIAL COSTS, EXPENSES, OR DAMAGES INCURRED BY THE CONSUMER OR ANY OTHER USER.

Some states do not allow the exclusion or limitation of implied warranties or consequential damages, so the above limitations or exclusions may not apply to you.

LEGAL REMEDIES

This warranty gives you specific legal rights, and you may also have other rights that vary from state to state.

WARRANTY PERFORMANCE

During the above three-month warranty period, your Disk Controller and Disk Manager module will be repaired or replaced with a new or reconditioned unit of the same or equivalent model (at TI's option) when the unit is returned by prepaid shipment to a Texas Instruments Service Facility listed below. The repaired or replacement unit will be warranted for three months from date of repair or replacement. Other than the postage requirement, no charge will be made for the repair or replacement of in-warranty units.

Texas Instruments strongly recommends that you insure the unit for value prior to shipment.

TEXAS INSTRUMENTS CONSUMER SERVICE FACILITY*U.S. Residents*

Texas Instruments Service Facility
2303 North University
Lubbock, Texas 79415

Canadian Residents

Geophysical Services Incorporated
41 Shelley Road
Richmond Hill, Ontario, Canada L4C5G4

Consumers in California and Oregon may contact the following Texas Instruments offices for additional assistance or information.

Texas Instruments Consumer Service
831 South Douglas Street
El Segundo, California 90245
(213) 973-1803

Texas Instruments Consumer Service
10700 Southwest Beaverton Highway
Park Plaza West
Beaverton, Oregon 97005
(503) 643-6758